

Answer Key

Lesson 1-2

3. 4.

Lesson 1-8

$$\begin{aligned}
 19. \quad & 6(g + a) + 3g = 6g + 6a + 3g && \text{distributive property} \\
 & = 6g + 3g + 6a && \text{commutative property (+)} \\
 & = (6g + 3g) + 6a && \text{associative property (+)} \\
 & = (6 + 3)g + 6a && \text{distributive property} \\
 & = 9g + 6a && \text{substitution (=)}
 \end{aligned}$$

Chapter 1 Review

- $5 \cdot 1 + 6 \div 2 = 8$
- $3 \cdot (8 + 2) = 30$
- $9 \div (5 - 8 \div 4)^2 = 1$
- $2x + 7x + 6y + 8x = 17x + 6y$
- $5(n + 1) + 3(n + 6) = 8n + 23$
- $6 + 5 = 5 + 6$; commutative property (+)

Lesson 2-1

-
-
-
-
-
-

Lesson 2-2

-
-

Chapter 2 Review

- 1a. 1°C 1b. 5°C 1c. -7°C 1d. 3°C
 1e. -2°C 1f. 21°C 2. Berlin: 34°F ; London: 42°F ; Montreal: 18°F ; Paris: 38°F ; Beijing: 28°F ; Sao Paulo: 74°F 3. Sao Paulo, Brazil, is in the southern hemisphere, and December is summertime in the southern hemisphere. 4. Answers will vary.

Chapter 3 Review

1. -3 2. 5 3. -12 4. 6 5. 7 6. -30
 7. -7 8. 31 9. -9 10. 4 11. 8
 Solution to puzzle: algebra is fun

Lesson 4-7

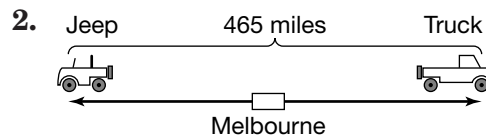

Chapter 4 Review

Answers will vary depending on the number of children and adults that students observe. The following are sample answers.

1.

	Location 1	Location 2	Location 3
Children	32	18	24
Adults	48	14	51
Total	80	32	75
Ratio of children to total	$\frac{2}{5}$	$\frac{9}{16}$	$\frac{8}{25}$
Ratio of adults to total	$\frac{3}{5}$	$\frac{7}{16}$	$\frac{17}{25}$

2.

	Location 1	Location 2	Location 3
Number of children out of 50	20	28	16
Number of adults out of 50	30	22	34

3. In the community, about 40% of the people are children and 60% are adults.

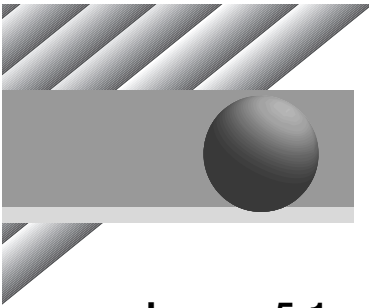

Answer Key

Lesson 5-1

10-19.

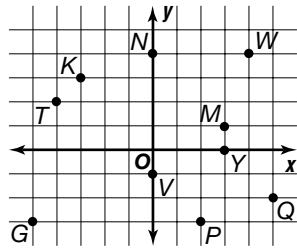

Lesson 5-4

2. $y = 3x - 5$

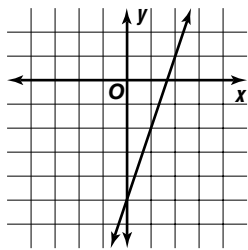

9.

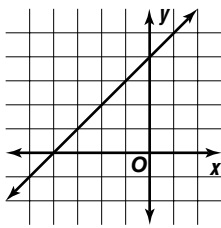

10.

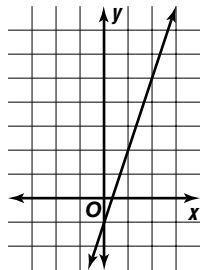

11.

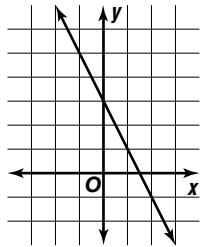

12.

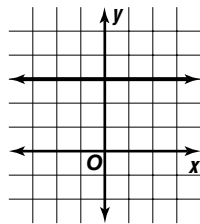

13.

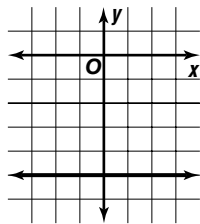

14.

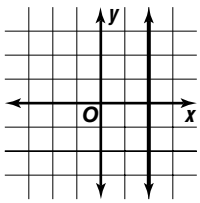

15.

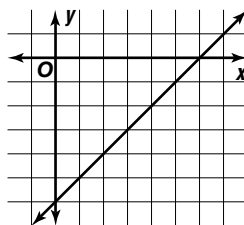

16.

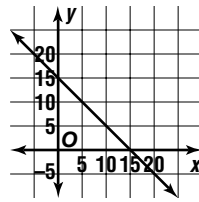

17.

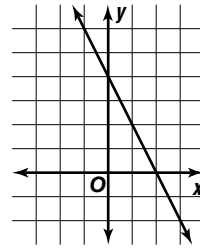

Chapter 5 Review

Clue 1: $D = \{0, 5\}$; $R = \{1, 3\}$

Clue 2: $\{(0, 5), (-2, 4), (-2, 3)\}$

Clue 3: The points are: $(-2, -1)$, $(-1, 0)$, and $(2, 3)$.

Clue 4: no; yes; yes

Clue 5: 4

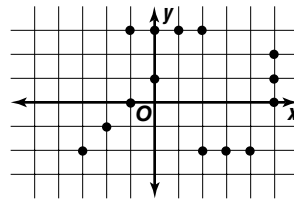

Lesson 6-5

1.

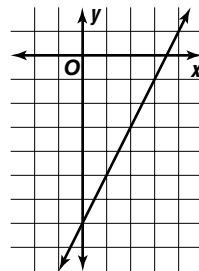

2.

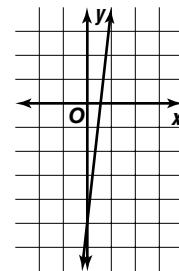

3.

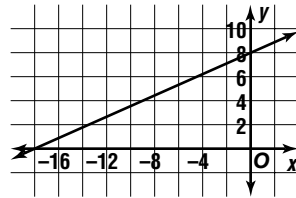

4.

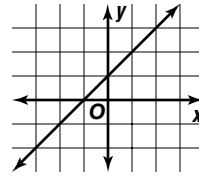

5.

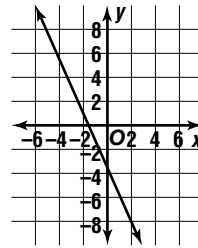

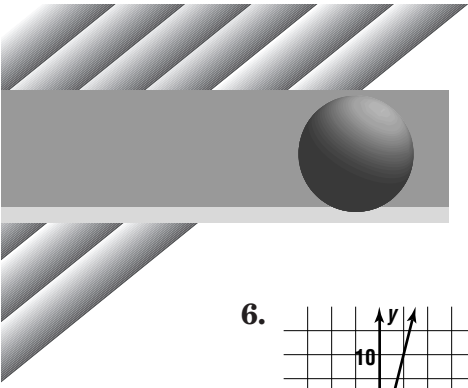

Answer Key

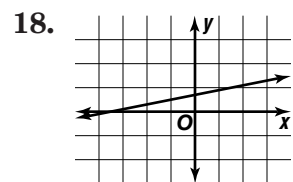
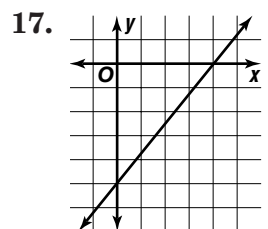
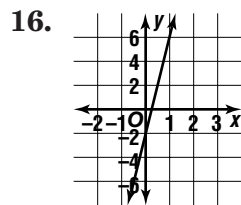
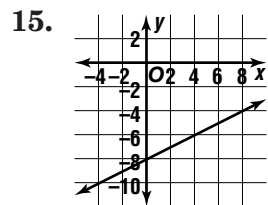
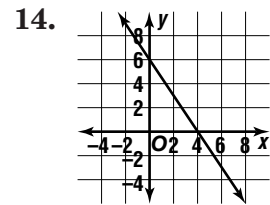
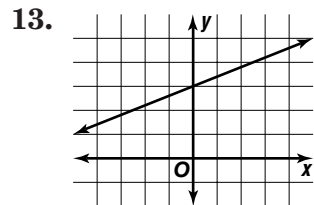
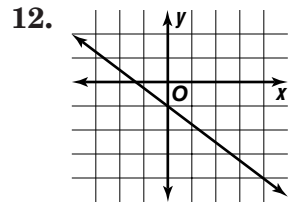
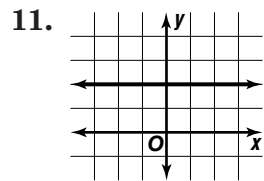
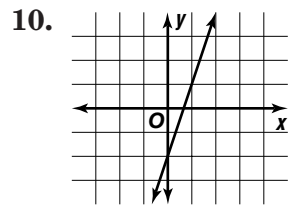
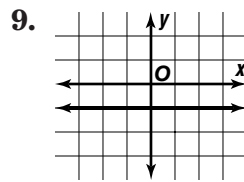
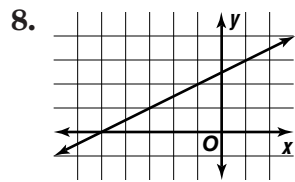
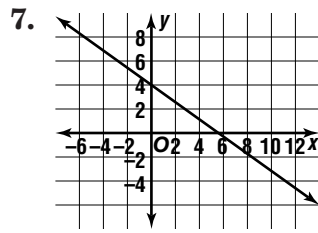
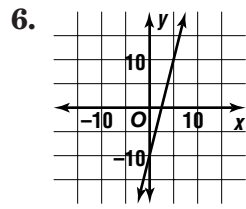

Chapter 6 Review

- $m = -2$
- $m = 0$
- undefined slope
- $y = 5$
- $x = -5$
- Sample answer: $y - 3 = 2(x + 5)$.
- $m = -\frac{7}{5}$
- $y = -x + 3$

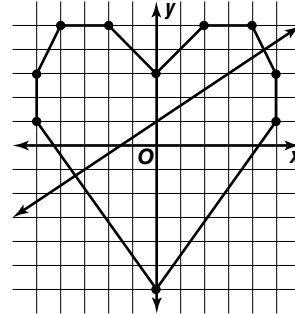

Lesson 7-1

-
-
-
-
-
-

Lesson 7-4

-
-
-
-
-
-
-

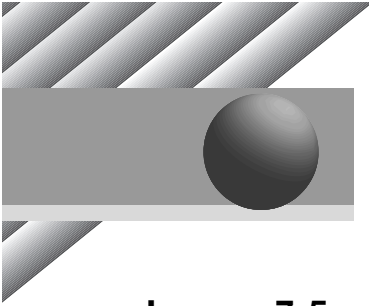

Answer Key

Lesson 7-5

1a. Question 1 Question 2 Outcomes

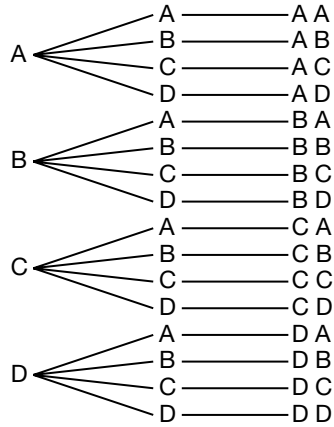

2a. Bread Meat Cheese Outcomes

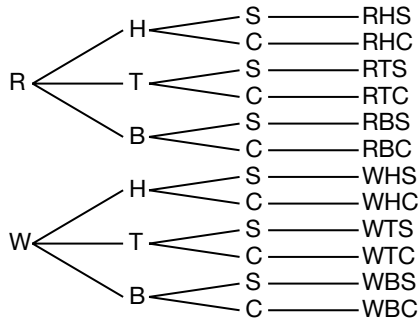

Lesson 7-6

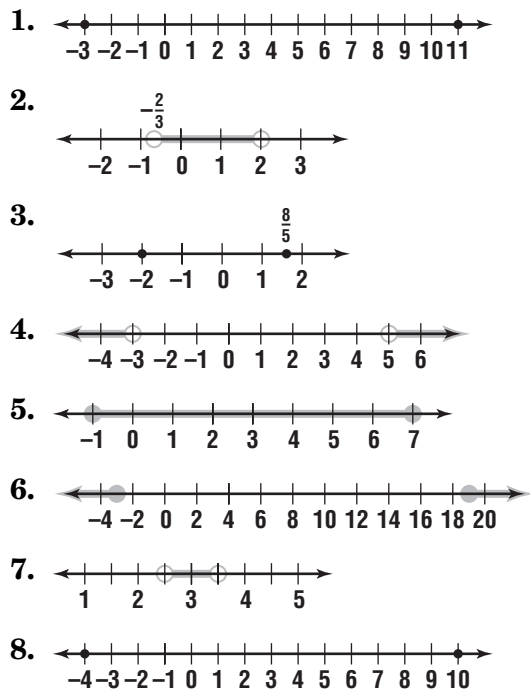

Lesson 7-7

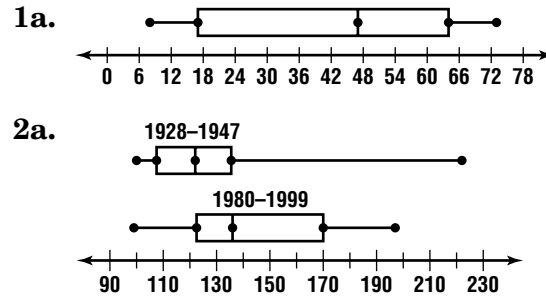

Lesson 7-8

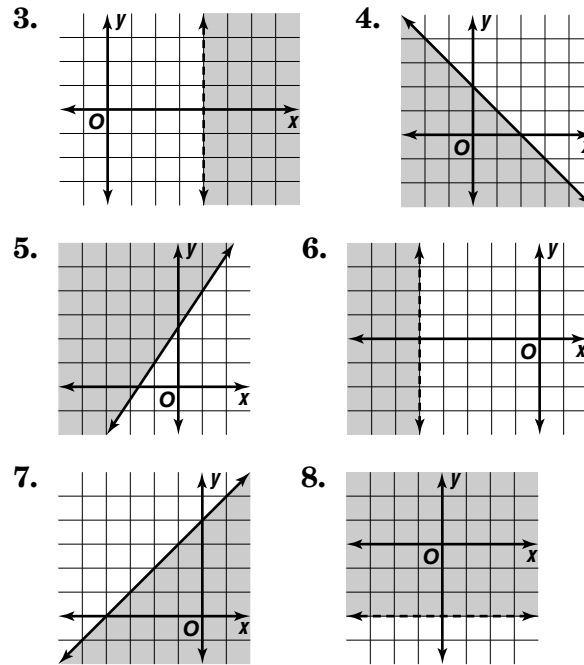

Chapter 7 Review

1. $x \leq 4$ 2. $t > 4$ 3. $n < 4$ 7. $w < 5$ and $w > -3$ 9. $p \geq 5$ or $p \leq -3$
 NY YANKEES TICKETS

Lesson 8-1

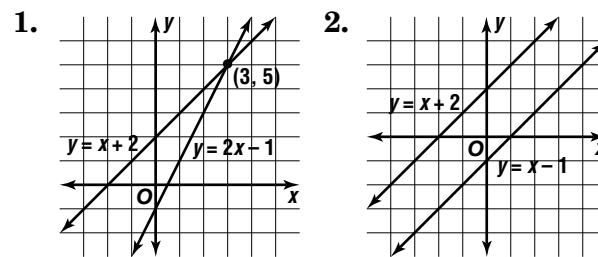

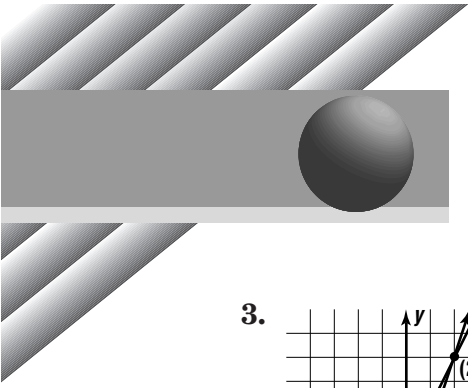

Answer Key

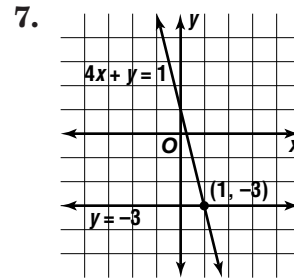
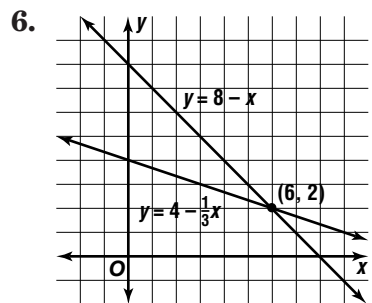
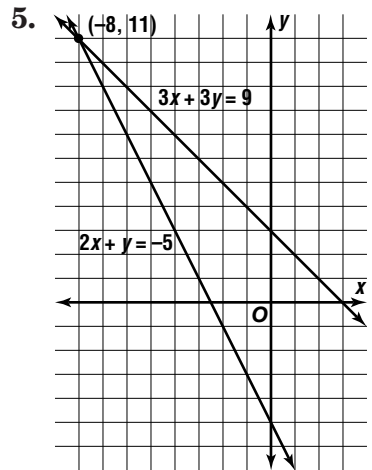
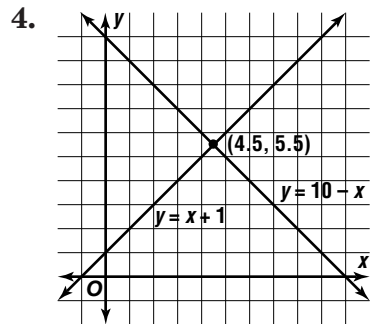
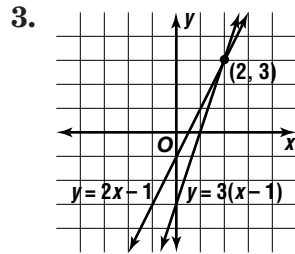

Lesson 8-5

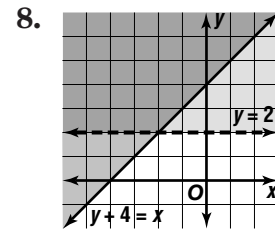
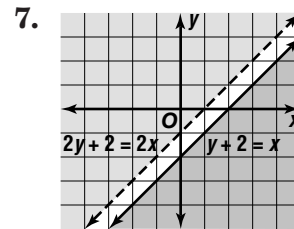
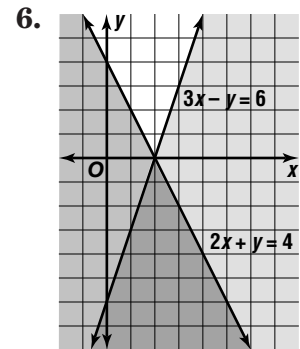
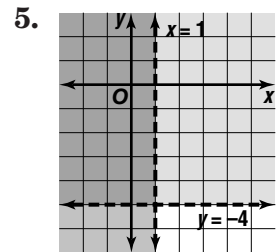
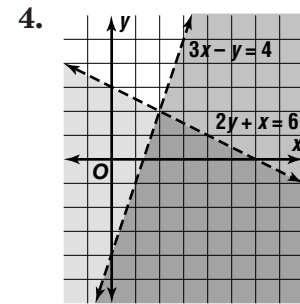
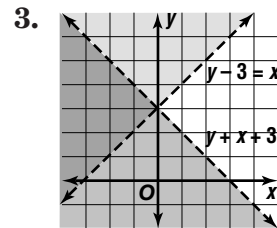
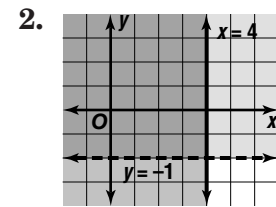
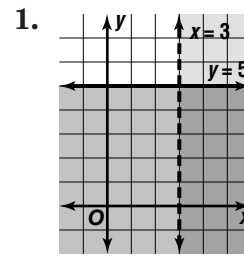

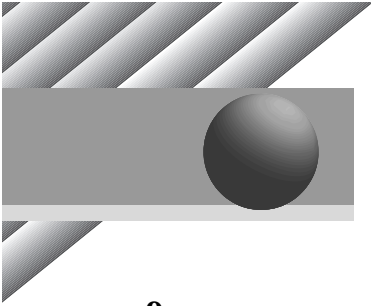

Answer Key

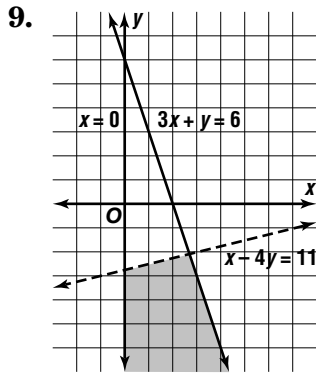

Chapter 8 Review

Gold: $(-2, 4)$; Silver: $(4, -3)$; Diamonds: no solution; Jewels: $(-1, 0)$; The gold is nearest to the starting point, $(0, 5)$.

Chapter 9 Review

1. $18x^7$ 2. $2x$ 3. $2x^3 - 6x^2 - 2x$
 4. $2x^3 + 2x$ 5. $x + 5$ 6. $x^2 + 11x + 30$
 7. 6.5×10^2 8. 2.47×10^6
 2,470,000; \$24,700

Chapter 10 Review

1. $9x(2 - y)$ 2. $2x(2x^2 + 3)$
 3. $(x - 8)(x + 8)$ 4. $(x - 4)(x + 4)$
 5. $2(x - 4)(x + 4)$ 6. $(x + 2)(x + 4)$
 7. $(x - 4)(x - 2)$ 8. $(x - 3)(x + 4)$
 9. $(x - 4)(x + 3)$ 10. $(x + 2)(x + y)$
 11. $(x + 4)(y - x)$ 12. $(x + 4)(x + 2y)$
 The outdated technology: EIGHT TRACK

Lesson 11-1

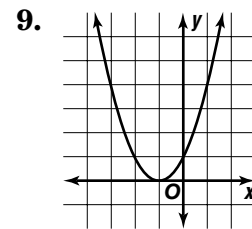
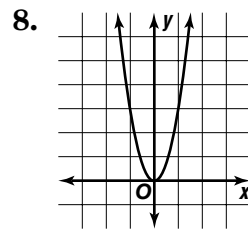
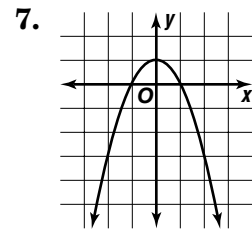
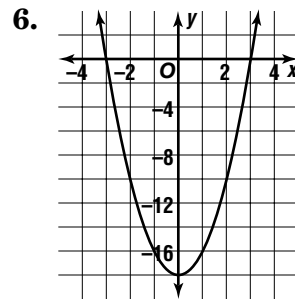
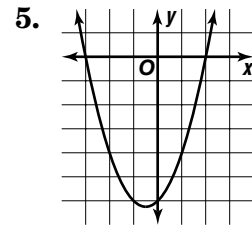
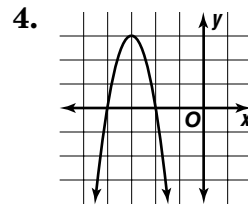
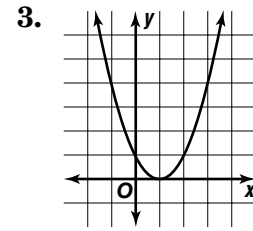
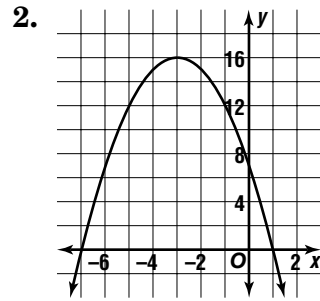
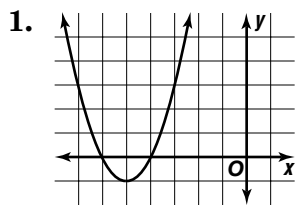

Lesson 11-4

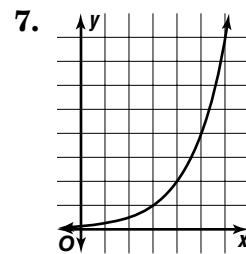
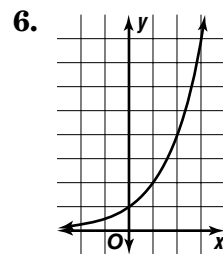

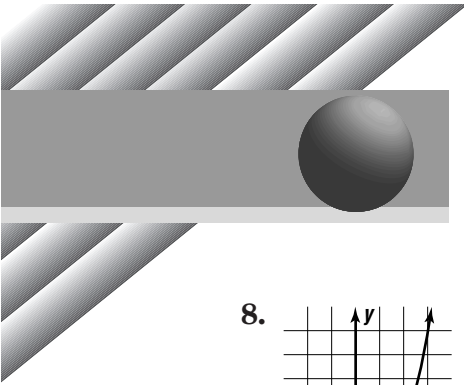

Answer Key

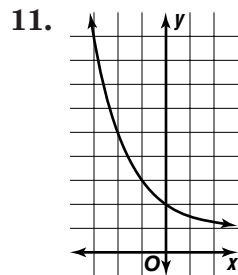
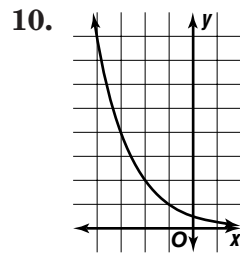
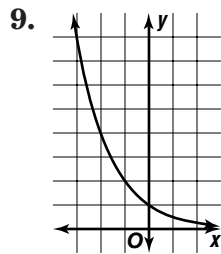
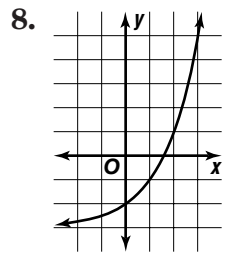

Chapter 11 Review

Hole 1: $y = -x^2 + 2x + 5$

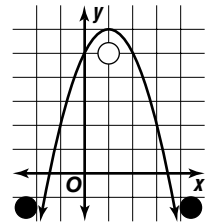

Hole 2: $y = x^2 - 6x + 1$

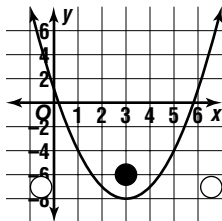

Hole 3: $y = -2x^2 + 12x$

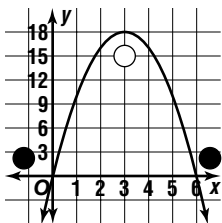

Hole 4: $y = 4x^2 - 8x + 4$

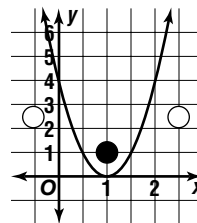

Chapter 12 Review

1. $\frac{3x}{y}$ 2. $\frac{x}{3}$ 3. $\frac{x+4}{2x+4}$ 4. 1 5. $x^2 + 2x - 1$
 6. 6 7. $\frac{-8}{35x}$ 8. $\frac{x^2 - 3x + 1}{x - 3}$

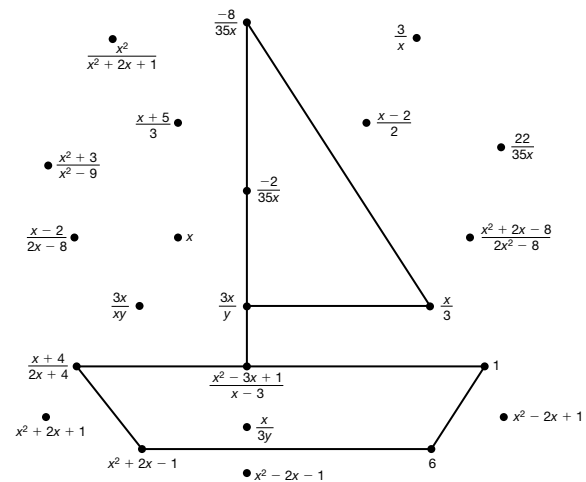

Chapter 13 Review

1. 8 (X—Leaky Roof) 2. $4|x|\sqrt{5}$
 3. $6b^2|c|\sqrt{2ab}$ 4. 3 (X—Leaky Roof)
 5. $\sqrt{6}$ 6. $-3\sqrt{5} + 4\sqrt{7}$
 7. 0 (X—Leaky Roof) 8. $3 + 2\sqrt{3}$
 9. -32 (X—Leaky Roof) 10. $\frac{30 - 5\sqrt{3}}{33}$