

12-1

Drawing Three-Dimensional Figures

(pages 514–517)

Three-dimensional figures are called **solids**. You can use a **perspective** drawing to show the three dimensions of a solid in a two-dimensional drawing.

EXAMPLE

Make a perspective drawing using the top, side, and front views of the figure below.

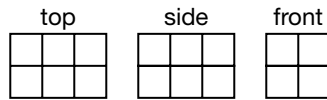

<p>Step 1 Sketch a 2-by-3 rectangle for the top.</p>	<p>Step 2 Add the front and side views.</p>	<p>Step 3 Add dashed lines to show the hidden edges.</p>
---	--	---

PRACTICE

Draw a top, a side, and a front view of each figure.

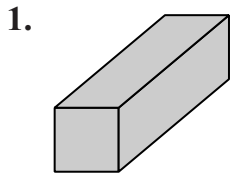

Make a perspective drawing of each figure by using the top, side, and front views as shown. Use isometric dot paper if necessary.

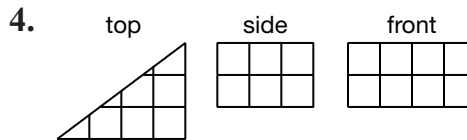
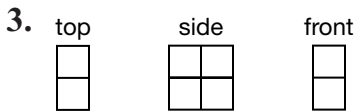

5. **Standardized Test Practice** What kind of solid has the top view of a circle, the side view of a triangle, and the front view of a triangle?

- A** cone **B** pyramid **C** triangular prism **D** cylinder

Answers: 1–4. See Answer Key. 5. A

12-2

Volume of Rectangular Prisms

(pages 520–522)

A **rectangular prism** is a solid figure that has two parallel and congruent sides, or bases, that are rectangles. The **volume** of a solid figure is the measure of the space it occupies. You can find the volume of a rectangular prism with the following formula.

Volume of a Rectangular Prism	Find the volume (V) of a rectangular prism by multiplying the area of the base (B), length (ℓ) times width (w), by the height (h). $V = Bh$ or $V = \ell wh$
--------------------------------------	--

EXAMPLE

What is the volume of a rectangular prism with a length of 7 meters, a width of 4 meters, and a height of 10 meters?

$$V = \ell wh$$

$$V = 7 \times 4 \times 10 \quad \text{Substitute the values for the length, width, and height.}$$

$$V = 280$$

The volume is 280 cubic meters.

PRACTICE

Find the volume of each rectangular prism to the nearest tenth.

1.

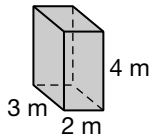

2.

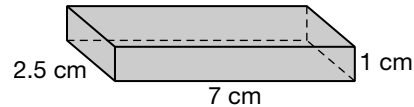

3.

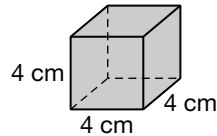

4.

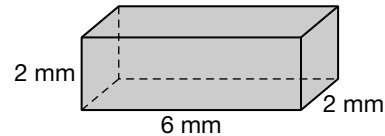

5.

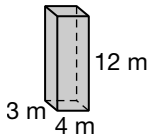

6.

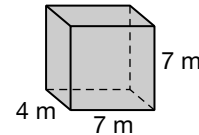

7. **Hobbies** The height of a fish tank is 10 inches and the base measures 20 inches by 12 inches. What volume of water can the tank hold when full?



8. **Standardized Test Practice** A 50-pound bag of peanuts is 2 feet by 4 feet by 1 foot. If a 50-cubic-foot space is available for storing the bags, how many can be stored?

A 5

B 6

C 7

D 8

Answers: 1. 24 m³ 2. 17.5 cm³ 3. 64 cm³ 4. 24 mm³ 5. 144 m³ 6. 196 m³ 7. 2,400 in³ 8. B

12-3

Volume of Cylinders (pages 524–527)

A stack of coins is a model of a **cylinder**. A cylinder is a solid figure that has two congruent, parallel circles as its bases. Use the formula below to find the volume of a cylinder.

Volume of a Cylinder	Find the volume (V) of a cylinder by multiplying the area of the base (πr^2) by the height (h). $V = Bh$ or $V = \pi r^2 h$
-----------------------------	---

EXAMPLE

Find the volume of a cylinder with a diameter of 8 centimeters and a height of 10 centimeters.

The diameter of the cylinder is 8 cm. Therefore, the radius is 4 cm.

Estimate: $4^2 \times 3 \times 10 = 480$

$$V = \pi r^2 h$$

$$V \approx 3.14 \times 4^2 \times 10 \quad \text{Substitute the values for } \pi, r, \text{ and } h.$$

$$V \approx 502.4$$

The cylinder has a volume of about 502 cubic centimeters.

Try These Together

Find the volume of each cylinder to the nearest tenth.

1. diameter, 2 m; height, 5 m

HINT: Change the diameter to the radius and then find the area of the base. Multiply the area of the base by the height.

2. radius, 8 in.; height, 14 in.

HINT: Find the area of the base and then multiply it by the height.

PRACTICE

Find the volume of each cylinder to the nearest tenth.

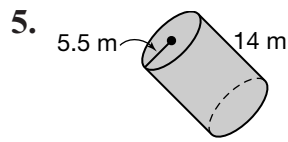
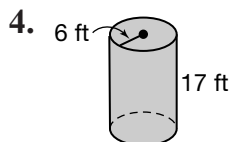
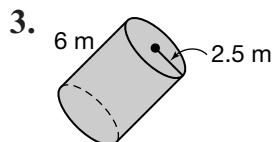

6. **Packaging** The diameter of a can of tuna is 3 inches and the height is 2 inches. Find the approximate volume of the can.

7. **Standardized Test Practice** Stella has a can full of water that is 6 cm tall and 8 cm in diameter. She wants to pour the water into a can that is 4 cm in diameter. How tall must the can be?

A 12 cm

B 3 cm

C 24 cm

D 18 cm

Answers: Answers are calculated using the π key on a calculator and then rounded. 1. 15.7 m³ 2. 2,814.9 in.³ 3. 117.8 m³ 4. 1,922.7 ft³ 5. 1,380.5 m³ 6. about 14.1 in.³ 7. C

12-4

Surface Area of Rectangular Prisms

(pages 532–535)

Surface area is the sum of the areas of all of the outside surfaces of a three-dimensional figure. Use the formula below to find the surface area of a rectangular prism.

Surface Area of a Rectangular Prism	The surface area of a rectangular prism equals the sum of the areas of the faces. $S = 2\ell w + 2\ell h + 2wh$, where ℓ = length, w = width, and h = height.
--	--

EXAMPLE

Find the surface area of a cardboard carton with a length of 4 feet, a width of 3 feet, and a height of 2 feet.

$$S = 2\ell w + 2\ell h + 2wh$$

$$S = 2 \times 4 \times 3 + 2 \times 4 \times 2 + 2 \times 3 \times 2$$

$$S = 24 + 16 + 12$$

$$S = 52$$

Replace ℓ with 4, w with 3, and h with 2.
Multiply first.

The surface area of the carton is 52 square feet.

Try These Together

Find the surface area of each rectangular prism.

1. $\ell = 5$ mm, $w = 3$ mm, $h = 2$ mm

2. $\ell = 10$ cm, $w = 4$ cm, $h = 6$ cm

HINT: Multiply each area you find by 2 to account for the six surfaces of the prism.

PRACTICE

Find the surface area of each rectangular prism.

3.

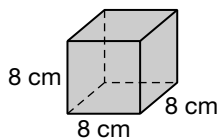

4.

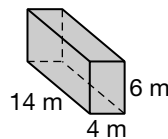

5.

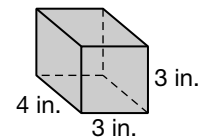

6. **Hobbies** Bob wants to display some of his photographs. Which has more surface area, a 4 inch by 4 inch by 4 inch photo cube, or a 3 inch by 4 inch by 5 inch prism?



7. **Standardized Test Practice** A box is 6 in. by 9 in. by 2 in. How many square inches of wrapping paper would it take to gift wrap this box?

A 168 in^2

B 84 in^2

C 126 in^2

D 336 in^2

Answers: 1. 62 mm^2 2. 248 cm^2 3. 384 cm^2 4. 328 m^2 5. 66 in^2 6. the cube 7. A

12-5

Surface Area of Cylinders (pages 538–541)

Use the formula below to find the surface area of a cylinder.

Surface Area of a Cylinder	The surface area of a cylinder equals the sum of the areas of the circular bases ($2\pi r^2$) and the area of the curved surface ($2\pi rh$). $S = 2\pi r^2 + 2\pi rh$, where r = radius of the cylinder and h = height.
-----------------------------------	--

EXAMPLE

Find the surface area of a cylindrical drum with a radius of 2 feet, and a height of 5 feet.

$$S = 2\pi r^2 + 2\pi rh$$

$$S = 2 \times \pi \times 2^2 + 2 \times \pi \times 2 \times 5$$

$$S \approx 87.96$$

Replace r with 2 and h with 5.

Use a calculator.

The surface area of the drum is about 88 square feet.

Try These Together

Find the surface area of each cylinder to the nearest tenth.

1. $r = 6$ in.; $h = 10$ in.

2. $r = 10$ cm; $h = 30$ cm

HINT: Remember to add the areas of the bases to the area of the curved surface.

PRACTICE

Find the surface area of each cylinder to the nearest tenth.

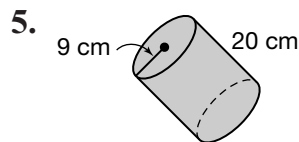
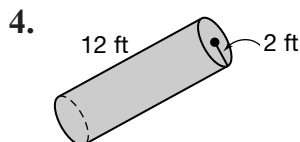
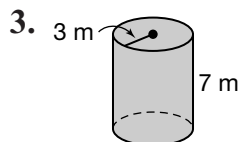

6. **Rocketry** Jule wants to paint his model rocket. The rocket is 28 inches tall and has a radius of 2 inches. He has enough paint to cover an area of 300 in^2 . Does he have enough paint to cover his rocket? *Hint:* The top of his rocket tube is an opening for the nosecone, and the bottom is an opening for the motor, so you only have to find the area of the curved surface.



7. **Standardized Test Practice** The diameter of a cylinder is 6 inches and the height is 11 inches. What is the surface area to the nearest square inch?

A 641 in^2

B 471 in^2

C 434 in^2

D 264 in^2

Answers: Answers are calculated using the π key on a calculator and then rounded. 1. 603.2 in^2 2. $2,513.3 \text{ cm}^2$ 3. 188.5 m^2 4. 175.9 ft^2 5. $1,639.9 \text{ cm}^2$ 6. no 7. D

12-6

Precision and Measurement (pages 542–545)

The **precision** or **exactness** of a measurement depends on the unit of measure. The **precision unit** is the smallest unit on a measuring tool. The smaller the unit, the “more precise” the measurement is.

All measurements are approximate. A more precise method is to use significant digits. **Significant digits** include all of the digits of a measurement that you know for sure, plus one estimated digit.

EXAMPLE

Identify the precision unit of the ruler shown. Then use significant digits to find the measure of the pencil.

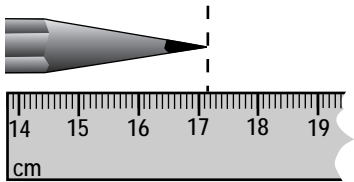

The smallest unit is one tenth of a centimeter. The precision unit is 0.1 centimeter. You know for certain that the length is between 17.1 and 17.2 centimeters. One estimate is 17.15 centimeters.

Try These Together

1. Identify the precision unit of the ruler below.
2. Use significant digits to find the measure of the line.



HINT: What is the smallest unit of measure?

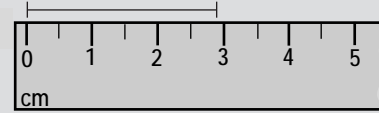

HINT: Identify two measures that the line is between.

PRACTICE

Use significant digits to find the measure of each line.

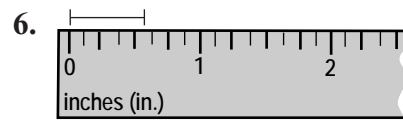
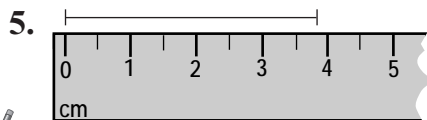
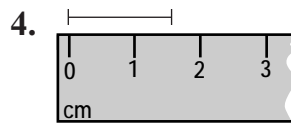
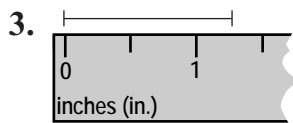

7. **Standardized Test Practice** Choose the best precision unit for estimating the length of a bedroom.

- A** 0.1 cm **B** 0.5 in. **C** 0.5 ft. **D** 0.1 mi

Answers: 1. $1\frac{8}{16}$ in. 2-6. Sample answers are given. 2. 2.75 cm 3. 1.25 in. 4. 1.5 cm 5. 3.75 cm 6. $1\frac{16}{16}$ in. 7. C

12**Chapter 12 Review****Prize by Volume**

Suppose you have just won a raffle. For your prize, you get to fill a container with quarters. You can keep all of the quarters you can fit into the container. Choose from the following containers.

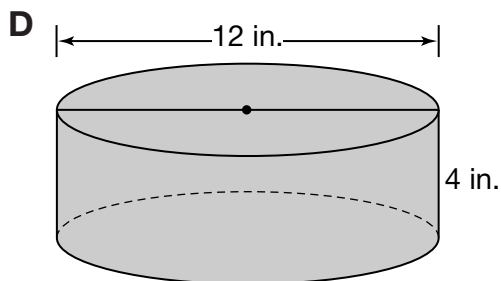
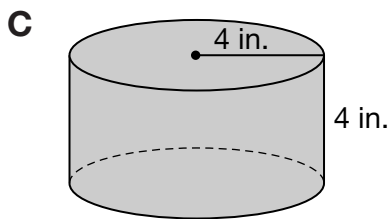
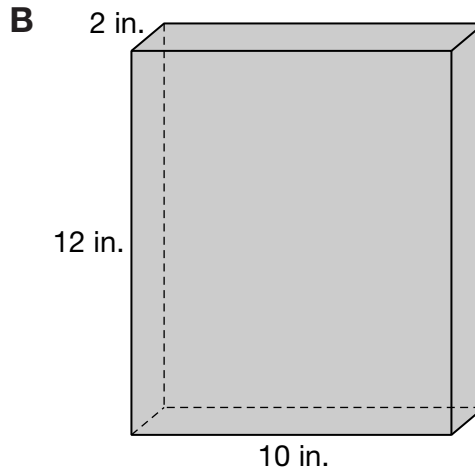
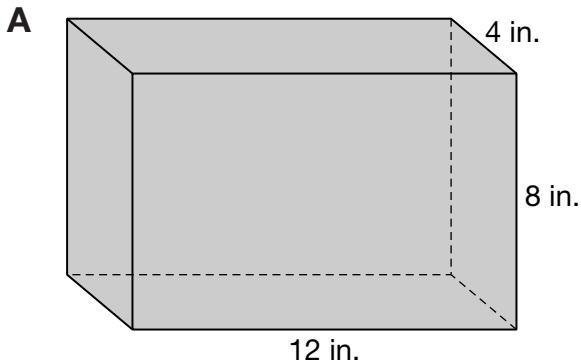

Which container would you choose if you wanted to get the most money?
Explain how you know.

Answers are located on page 108.