

Chapter 10

Use with Section 3

REINFORCEMENT**• Destruction by Earthquakes**

Write the names of the seismograph parts illustrated on the lines provided.

- A. _____
 B. _____
 C. _____
 D. _____

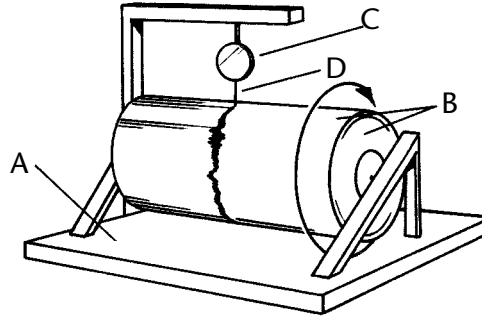

Use the table titled "Large Magnitude Earthquakes" in your text to help you answer the following questions.

- When and where was the strongest earthquake listed in the table? _____
- How many earthquakes on the chart had a Richter value of 8.3? _____
- Where were the earthquakes that had a Richter value of 8.3? _____

- Why might so many more people have died in the Tokyo earthquake than in the New Madrid earthquake? _____

- The earthquake in southern Chile was 32 times stronger than which other earthquake? _____

- Which earthquakes occurred in North America? _____

- Which earthquakes were 32 times greater than an earthquake registering 7.1 would be? _____
