

CHAPTER REVIEW

Chapter 4

Work and Energy

I. Vocabulary Review

Solve the puzzle below by writing the term in the diagram that best completes each statement.

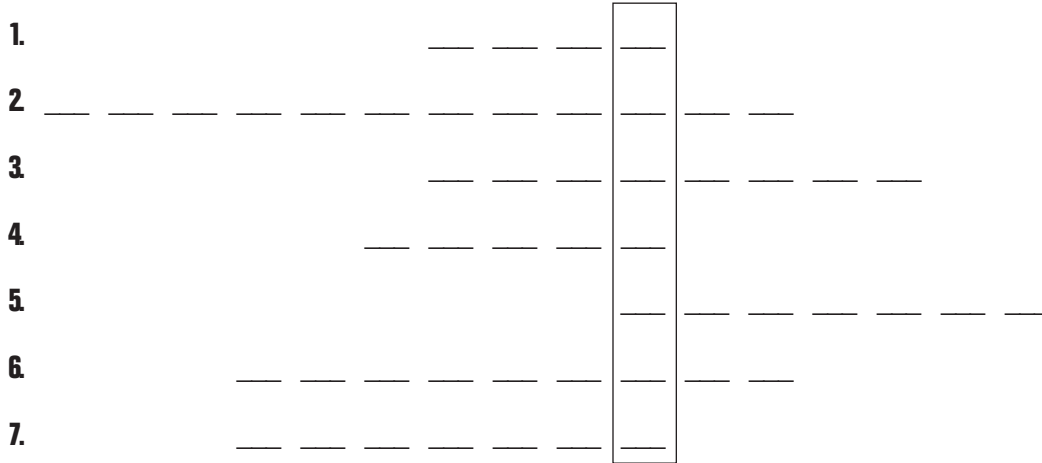

- Force times distance equals _____.
- In the law of _____ of energy, energy can be neither created, nor destroyed.
- When energy changes form, a _____ of energy takes place.
- A unit of work and energy in SI is the _____.
- The type of energy felt as heat is _____ energy.
- Stored energy is known as _____ energy.
- Energy stored when stretching something is known as _____ potential energy.
- Use the boxed letters to complete this statement: Energy of motion is _____ energy.

II. Concept Review

Answer the following in complete sentences.

- You've been trying to move a heavy box, but it's so heavy it hasn't moved. You quit because you're tired. Have you done any work on that box? Why or why not? _____

- What has done more work, something that lifted an 8-kg box a distance of 2 m or something that lifted a 2-kg box a distance of 8 m? _____

- In a swinging pendulum, where is potential energy the greatest? _____

- What type of energy does a compressed spring store? _____

Chapter Review 4 (continued)

13. What happens to the potential energy in a jack-in-the-box when you release the lid? _____

14. If you had 70 J of potential energy and converted it into 55 J of kinetic energy, what accounts for the missing 15 J? _____

III. Skills/Process Review

15. Rank the following from 1 to 4 according to how much work is done. (1 is the most work done.)

_____ Math homework _____ Piano moving _____ Sleeping _____ Playing baseball

FIGURE 1

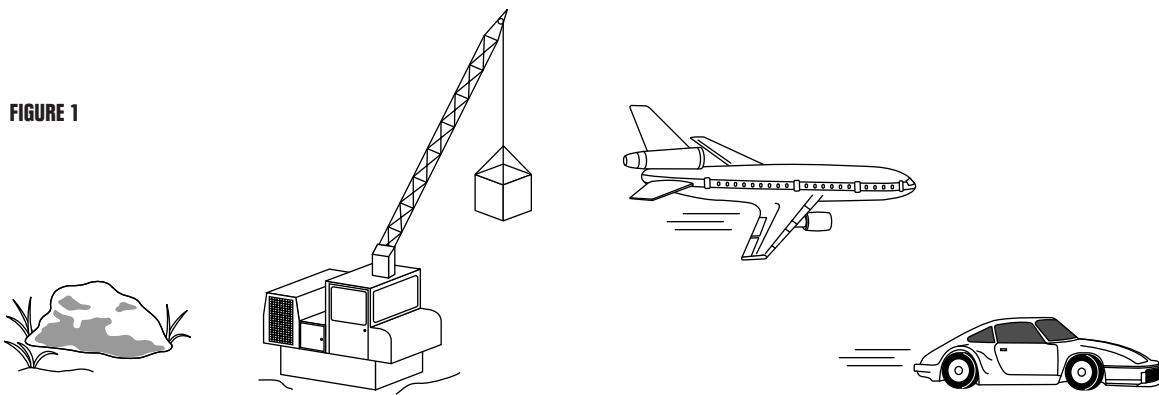

a. Rock on the ground

b. Large stone held by a crane

c. Flying jumbo jet

d. Racing sports car

Use the figure to answer the following. In the blank at the left, write the letter of the choice that best matches each description.

_____ 16. High potential energy and high kinetic energy

_____ 17. High potential energy and low kinetic energy

_____ 18. Low potential energy and high kinetic energy

_____ 19. Low potential energy and low kinetic energy

IV. EYV Review

20. **Technology Connection: The Search for Perpetual Motion** A perpetual motion machine is impossible to make because its friction produces thermal energy that ends up being distributed in the air. If we could create a frictionless machine, then could we create a perpetual motion

machine? If so, could we run other machines off the perpetual motion machine? _____