

# Area of Parallelograms

(pages 398–401)

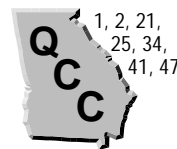
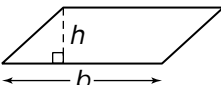

A rectangle is a special kind of parallelogram. A parallelogram is a quadrilateral with two pairs of parallel sides. The base is any one of the sides and the height is the shortest distance (the length of a perpendicular segment) from the base to the opposite side.

<b>Finding the Area of a Parallelogram</b>	The area ( $A$ ) of a parallelogram equals the product of its base ( $b$ ) and height ( $h$ ). $A = bh$	
--	--	---

## EXAMPLES

**A** Find the area of the parallelogram.

*Multiply the length of the base of the parallelogram (4 in.) and the height drawn to that base (5 in.).*

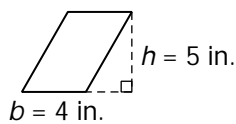

$$A = bh$$

$$A = 4(5)$$

$$A = 20 \text{ in}^2$$

**B** The area of a parallelogram is 30 square inches. The base is 10 inches long. What is the height?

$$A = bh$$

$$30 = 10h \quad \text{Substitute the values you know.}$$

$$h = 3 \quad 30 = 10 \cdot 3$$

The height is 3 inches.

## Try These Together

1. Find the area (to the nearest tenth) of a parallelogram that is 3.6 centimeters wide and 5.2 centimeters high.

*HINT: Use the formula and then round.*

2. Find the base of a parallelogram that has a height of 7 centimeters and an area of 56 square centimeters.

*HINT: Write the formula, substitute values, and solve for  $b$ .*

## PRACTICE

Find the area of each parallelogram.

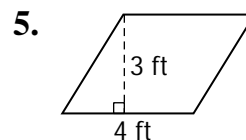
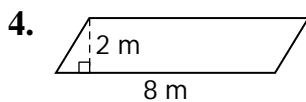
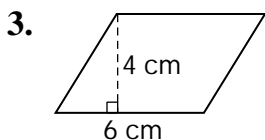

6. What is the area of a parallelogram that is 5 centimeters wide and 8 centimeters high?
7. **Puzzles** Kai has a puzzle that is a parallelogram. It is 30 centimeters long and 22 centimeters high. What is the area of the puzzle?



8. **Standardized Test Practice** If a parallelogram has an area of 42 square centimeters and its height is 6 centimeters, how long is its base?

- A** 6 cm                      **B** 7 cm                      **C** 5 cm                      **D** 8 cm

Answers: 1. 18.7 in<sup>2</sup> 2. 8 cm 3. 24 cm<sup>2</sup> 4. 16 m<sup>2</sup> 5. 12 ft<sup>2</sup> 6. 40 cm<sup>2</sup> 7. 660 cm<sup>2</sup> 8. B

## Area of Triangles (pages 402–405)

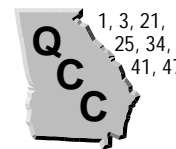

You can divide a parallelogram into two congruent triangles by drawing a diagonal. Each triangle has half of the area of the original parallelogram. Since the formula for the area of a parallelogram is  $A = bh$ , then the formula for the area of a triangle is  $A = \frac{1}{2}bh$ .

<b>Finding the Area of a Triangle</b>	The area ( $A$ ) of a triangle equals half of the product of the length of the base ( $b$ ) and the height ( $h$ ). $A = \frac{1}{2}bh$	
---------------------------------------	--	--

### EXAMPLES

**A** What is the area of a triangle with a height of 25 cm and a base of 36 cm?

$A = \frac{1}{2}bh$       Write the formula.

$A = \frac{1}{2}(36)(25)$       Substitute the values you know.

$A = 450 \text{ cm}^2$       Multiply to find the area.

**B** The area of a triangle is  $54 \text{ in}^2$  and the height is 12 in. Find the base.

$A = \frac{1}{2}bh$       Write the formula.

$54 = \frac{1}{2}(b)(12)$       Substitute the values you know.

$54 = 6b$       Multiply.

$9 \text{ in.} = b$        $54 = 6 \cdot 9$

### Try These Together

1. Find the area of a triangle that has a base of 1 yd and height of  $\frac{1}{3}$  yd.

*HINT: Use the formula and multiply.*

2. A triangle has a base of 8 cm and an area of  $64 \text{ cm}^2$ . Find the height.

*HINT: Substitute in the formula and solve for  $h$ .*

### PRACTICE

Find the area of each triangle.

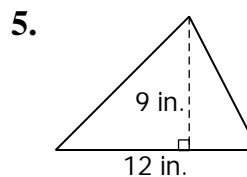
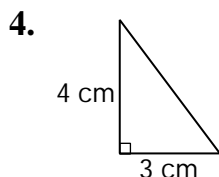
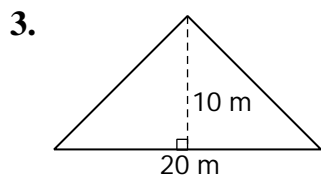

6. **Flags** The flag of the country of Guyana has a red triangle on it. If the base of the triangle is 30 inches and the height is 26 inches, what is the area of the triangle?

7. **Standardized Test Practice** How long is the base of a triangle that has an area of 63 square centimeters and a height of 7 centimeters?

- A** 7 cm      **B** 9 cm      **C** 16 cm      **D** 18 cm

Answers: 1.  $\frac{1}{3} \text{ yd}^2$  2. 16 cm 3.  $100 \text{ m}^2$  4.  $6 \text{ cm}^2$  5.  $54 \text{ in}^2$  6.  $390 \text{ in}^2$  7. D

# Area of Circles (pages 406–409)

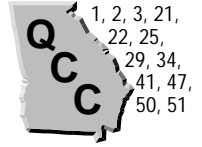

If you cut a circle into a number of equal-sized pie-shaped pieces and arrange them carefully, you can form a rough parallelogram. The height of the parallelogram is about equal to the radius of the circle. The base is about equal to  $\frac{1}{2}$  of the circumference of the circle. This would mean that the area is about  $\frac{1}{2}Cr$ . Substitute the circumference formula for  $C$  and you get the following equation.

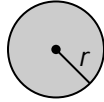
<b>Finding the Area of a Circle</b>	The area ( $A$ ) of a circle equals the product of $\pi$ and the square of the radius ( $r$ ). $A = \pi r^2$	
-------------------------------------	---	---

## EXAMPLES

**A** Find the area of a circle with a radius of 7 cm. Use 3.14 for  $\pi$ .

$$A = \pi r^2 \quad \text{Write the formula.}$$

$$A \approx 3.14(7)^2 \quad \text{Substitute the values you know.}$$

$$A \approx 154 \text{ cm}^2 \quad \text{Use a calculator and round.}$$

**B** Find the area of a circle that has a diameter of 5 inches. Use 3.14 for  $\pi$ .

$$A = \pi r^2 \quad \text{Write the formula.}$$

$$A \approx 3.14(2.5)^2 \quad r = \frac{1}{2}d \text{ or } 2.5 \text{ in.}$$

$$A \approx 19.6 \text{ in}^2 \quad \text{Use a calculator and round.}$$

## Try These Together

1. A circle has a radius of 2 in. What is its area? Use 3.14 for  $\pi$ .

*HINT: Write the formula and substitute.*

2. The diameter of a circle is 4.2 yd. Find its area. Use 3.14 for  $\pi$ .

*HINT: First find the radius.*

## PRACTICE

Find the area of each circle to the nearest tenth. Use 3.14 for  $\pi$ .

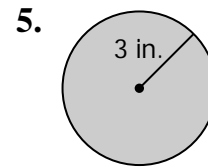
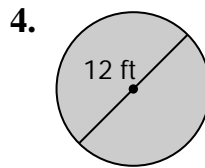
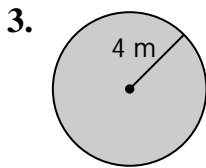

6. diameter, 18 centimeters

7. radius, 5 meters

8. radius, 10 inches



9. **Standardized Test Practice** What is the area of a circle that has a diameter of 30 centimeters?

A 353.3 square centimeters

B 2,826 square centimeters

C 176.6 square centimeters

D 706.5 square centimeters

Answers: 1. about 12.6 in<sup>2</sup> 2. about 13.8 yd<sup>2</sup> 3. 50.2 m<sup>2</sup> 4. 113.0 ft<sup>2</sup> 5. 28.3 in<sup>2</sup> 6. 254.3 cm<sup>2</sup> 7. 78.5 m<sup>2</sup> 8. 314.0 in<sup>2</sup> 9. D

## Three-Dimensional Figures

(pages 412–414)



A **three-dimensional** figure encloses a part of space. The flat surfaces are called **faces**. The segments formed by the intersecting faces are the **edges**. The edges intersect at the **vertices**.

<p><b>Naming Three-Dimensional Figures</b></p>	<ul style="list-style-type: none"> <li>• <b>prism</b>: two parallel and congruent faces, called <b>bases</b></li> <li>• <b>pyramid</b>: triangular faces; one base</li> </ul> <p>Prisms and pyramids are named by the polygon(s) at their base(s).</p> <ul style="list-style-type: none"> <li>• <b>cone</b>: curved surface; one circular base</li> <li>• <b>cylinder</b>: curved surface; two circular bases</li> <li>• <b>sphere</b>: all the points are the same distance from the center</li> </ul>
--	---

### EXAMPLES

**A** Name this figure.

*The faces are rectangular, so the figure is a prism.*

*The bases are rectangles, so it is a rectangular prism.*

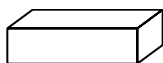

**B** Name this figure.

*The surface is curved and there are two circular bases.*

*The figure is a cylinder.*



### Try These Together

1. Is a square a two-dimensional or a three-dimensional figure?

*HINT: Does a square have the three dimensions of length, width, and height?*

2. How many faces, edges, and vertices are there in the figure of Example A?

*HINT: Think of a closed box shape.*

### PRACTICE

Name each figure.

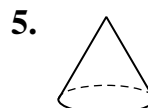
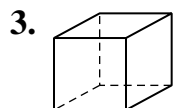

6. How many edges does this rectangular prism have?

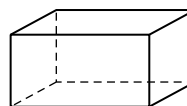

7. **Gift Wrapping** Juanita bought her mother a candle in the shape of a square pyramid for her birthday. How many faces does the candle have for Juanita to cover with wrapping paper?



8. **Standardized Test Practice** How many faces does a triangular pyramid have?

A 4

B 3

C 5

D 2

Answers: 1. two-dimensional 2. 6; 12; 8 3. cube (or square prism) 4. sphere 5. cone 6. 12 7. 5 8. A

# Volume of Rectangular Prisms

(pages 418–420)

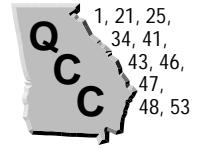

The amount of space inside a three-dimensional figure is called its **volume**. Volume is expressed in cubic units.

### Finding the Volume of a Rectangular Prism

The volume ( $V$ ) of a rectangular prism equals the product of its length ( $\ell$ ), its width ( $w$ ), and its height ( $h$ ).  
 $V = \ell wh$

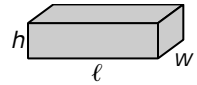

## EXAMPLES

- A** Find the volume of a rectangular prism that is 8 by 9 by 7 inches.

$$\begin{aligned} V &= \ell wh && \text{Write the formula.} \\ V &= 8(9)(7) && \text{Substitute the values you know.} \\ V &= 504 \text{ in}^3 && \text{Multiply to find the volume.} \end{aligned}$$

- B** A cereal box is 29 cm tall and its top measures 7 cm by 20 cm. Find the volume.

$$\begin{aligned} V &= \ell wh && \text{Write the formula.} \\ V &= 20(7)(29) && \text{Substitute the values you know.} \\ V &= 4,060 \text{ cm}^3 && \text{Multiply to find the volume.} \end{aligned}$$

## Try These Together

1. What is the volume of a storage shed 7 feet high with a floor that is 10 feet by 9 feet?

*HINT: Do you know the length, width, and height?*

2. A rectangular prism has a height of 2 yards, a width of 0.6 yards, and a length of 1.4 yards. Find the volume.

*HINT: Write the formula and substitute.*

## PRACTICE

Find the volume of each rectangular prism.

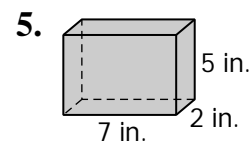
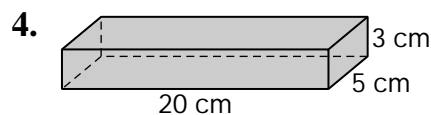
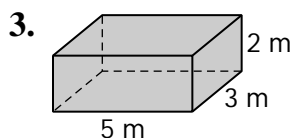

6. What is the volume of a rectangular prism that 12 mm high, 10 mm wide, and 18 mm long?
7. **Hobbies** Mr. Maki is building a new flower bed. The bed is 3 feet wide, 10 feet long, and 1.5 feet deep. How many cubic feet of dirt will he need for his new flower bed?



8. **Standardized Test Practice** Find the volume of a rectangular prism that is 5 feet wide, 8 feet tall, and 11 feet long.

**A** 55 ft<sup>3</sup>

**B** 880 ft<sup>3</sup>

**C** 440 ft<sup>3</sup>

**D** 40 ft<sup>3</sup>

Answers: 1. 630 ft<sup>3</sup> 2. 1.68 yd<sup>3</sup> 3. 30 m<sup>3</sup> 4. 300 cm<sup>3</sup> 5. 70 in<sup>3</sup> 6. 2,160 mm<sup>3</sup> 7. 45 ft<sup>3</sup> 8. C

## Surface Area of Rectangular Prisms (pages 421–424)

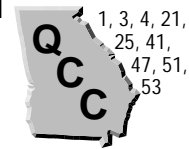

The **surface area** of a three-dimensional object is the total area of its faces and curved surfaces. The opposite sides of a rectangular prism have the same area.

<p><b>Finding the Surface Area of a Rectangular Prism</b></p>	<ul style="list-style-type: none"> <li>• Find the area of the top and bottom bases.</li> <li>• Find the area of the front and back faces.</li> <li>• Find the area of the right and left sides.</li> </ul> <p>Add all these areas to find the total surface area of the prism.</p>
---	--

### EXAMPLES

**A** Find the surface area of a box that is 8 ft by 6 ft by 3 ft.

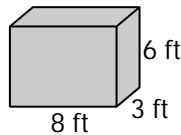

Area of the top is  $8 \times 3$ .  
 Area of the front is  $6 \times 8$ .  
 Area of the side is  $3 \times 6$ .  
 There are 2 of each face.  
 Total area =  $2(24) + 2(48) + 2(18)$  or  $180 \text{ ft}^2$

**B** What is the surface area of a rectangular prism with length = 3 in., width = 7 in., and height = 2 in.?

Area =  $2(3 \times 7) + 2(3 \times 2) + 2(7 \times 2)$   
 Area =  $2(21 + 6 + 14)$   
 Area =  $2(41)$   
 Area =  $82 \text{ in}^2$

### Try These Together

1. Find the surface area of a cube that has an edge of 3 yards.

*HINT: A cube is a rectangular prism with 6 congruent faces.*

2. Find the surface area of a rectangular prism that is 1.3 cm by 2.4 cm by 5.7 cm.

*HINT: Begin by making a sketch and labeling it.*

### PRACTICE

Find the surface area of each rectangular prism.

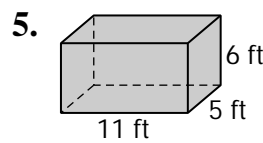
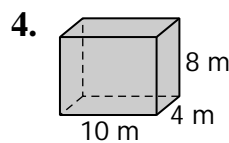
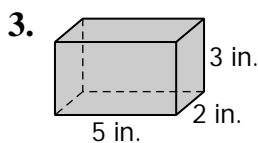

6. length = 12 ft  
width = 3 ft  
height = 8 ft

7. length = 3 cm  
width = 9 cm  
height = 1 cm

8. length = 5 m  
width = 7 m  
height = 8 m

9. **Decorating** Josie is putting wallpaper in her room. If her room is 10 feet wide, 12 feet long and 8 feet high, how much wallpaper will she need? Remember, she will not wallpaper the ceiling or the floor.



10. **Standardized Test Practice** What is the surface area of a 20-cm cube?

A 1,200  $\text{cm}^2$

B 2,400  $\text{cm}^2$

C 400  $\text{cm}^2$

D 4,400  $\text{cm}^2$

Answers: 1. 54  $\text{yd}^2$  2. 48.42  $\text{cm}^2$  3. 62  $\text{in}^2$  4. 304  $\text{m}^2$  5. 302  $\text{ft}^2$  6. 312  $\text{ft}^2$  7. 78  $\text{cm}^2$  8. 262  $\text{m}^2$  9. 352  $\text{ft}^2$  10. B

# Chapter 10 Review

## Geometry Carnival

1. You want to make a target like the ones you saw at a carnival. You want the bull's-eye at the center to have less than  $\frac{1}{10}$  of the area of the whole target. Does a target with the measurements shown at the right meet this requirement?

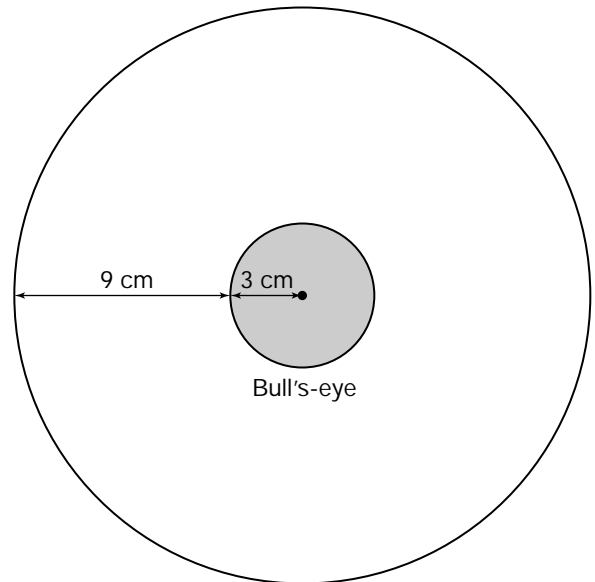

2. At the same carnival, you came across a very interesting game. Two tanks are partially filled with water as shown below. You must place solid prism C into one of the containers without spilling a drop of water to win a prize. Containers A and B are open on the top.

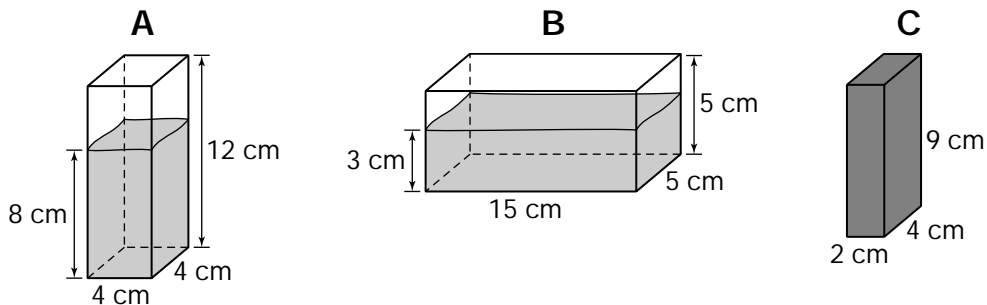

Into which container can you drop prism C without spilling water? Explain.

Answers are located on p. 110.